

Speed Dome IP Thermal Camera



Product overview

Speed Dome IP Thermal Camera is mainly developed based on the principle of infrared heat radiation. It is a non-contact, real-time, continuous and accurate temperature measurement device. It has the characteristics of low power consumption, and easy integration. The change of the target state, combined with the software system of the device, can visualize the temperature information of the temperature measurement object, and realize multiple functions such as equipment maintenance, fault detection, industrial process control, and quarantine. It can be widely used in electric power temperature measurement and industrial automation, inspection and quarantine and other fields.

Thermal imaging function

- ◆ The device supports front-end temperature measurement, and supports point, line, frame temperature measurement.
- ◆ High sensitivity detector, support contrast adjustment.
- ◆ Highest temperature cross cursor tracking and positioning.
- ◆ Temperature measurement accuracy: $\pm 2^{\circ}\text{C}$ or $\pm 2\%$ of reading, maximum value.
- ◆ Support timing, temperature difference and shutter correction in manual mode.
- ◆ Support 3D noise reduction function, adjustable false color, image detail enhancement function.
- ◆ Support mirror image, digital zoom and local video output.
- ◆ Rich network cable interface protocols, supporting RTSP, ONVIF and other protocols.
- ◆ Powerful data lossless compression performance (one real-time H.264 stream + one real-time temperature data stream).
- ◆ High temperature resistance, low power consumption, easy integration.

Application scenarios

It can be applied to various flammable, explosive and high-risk places such as electric power, hazardous chemical storage yards, warehouses, petroleum and petrochemicals, rotary kilns, solid waste and hazardous waste.

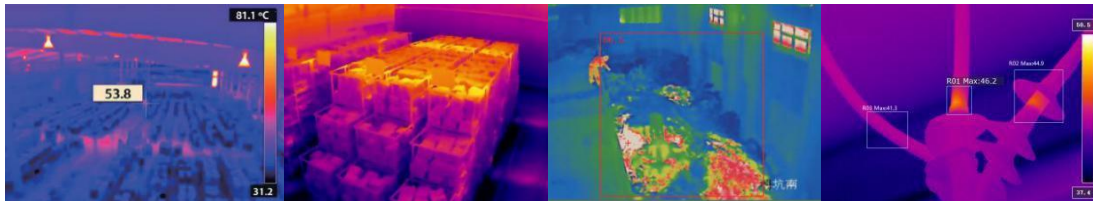

Technical parameter

Model	EX300-Q-6.5	EX300-Q-13	EX300-Q-18
Infrared performance			
Detector type	Uncooled FPA		
IR Resolution	384x288		
Spectral Range	8-14μm		
Thermal Sensitivity (NETD)	<40mk(@30°C)		
Field of View	6.5mm	13mm	18mm
Focal Length	45.4°x34.8°	24.5°x18.2°	17.1°x12.9°
Spatial resolution (IFOV)	2.61	1.30	0.94
Palette	10 color palettes		
Thermometric analysis	Infinite points, infinite boxes, infinite lines		
Object temperature range	-20 °C~150 °C (low temperature range), 0 °C~410°C (medium temperature range)		
Optional temperature range	+300 °C~+650 °C\+300 °C~+2000 °C\other ranges (high temperature range)		
Temperature measurement accuracy	±2°C or 2% of readings,maximum value		
Visible light performance			
Sensor type	1/2.8" Progressive Scan CMOS		
Resolution	1920×1080 2MP		
Focal length	4.8~120 mm, 25x optical zoom		
Field angle	57.6-2.5° (wide angle-telephoto)		
Minimum illumination	Color: 0.05 lux @(F1.6, AGC ON)\Black and white: 0.01 lux @ (F1.6, AGC ON)		
Focus	Manual/semi-automatic/automatic		
Wiper function	Support		

Fill light function	Infrared fill light, distance 150 meters
PTZ performance	
Horizontal range	0~360° continuous rotation
Vertical range	-27°~90°
Positioning accuracy	±0.05°
Horizontal speed	0.05°~200°/s
Vertical speed	0.05°~120°/s
Number of preset points	255
Cruise scan	8 lines, each line can add 32 preset points
Interface	
Power interface	φ5.5*2.1 DC power interface
Network interface	One 10M/100M adaptive Ethernet port
Network protocol	TCP/IP,IPv4,HTTP,FTP,DDNS,DHCP,RTP,RTSP,UDP,NTP,IGMP,ICMP, ONVIF
Application programming interface	Support standard protocol (ONVIF), support SDK access
System parameter	
Voltage supply	AC24V (±20%) \ DC24V (±20%)
Power	≤40W
Operating temperature and humidity	-40°C~70°C, < 90% RH
Protection level	IP66
Weight	7.76kg
Shell material	Die-cast aluminum

Model	EX600-Q-6.5	EX600-Q-13	EX600-Q-25	EX600-Q-50
Infrared performance				
Detector type	Uncooled FPA			
IR Resolution	640x512			
Spectral Range	8-14μm			
Thermal Sensitivity (NETD)	< 40mK (@30°C)			
Field of View	6.5mm	13mm	25mm	50mm
Focal Length	61.1°x47.7°	32.9°x24.9°	24.0°x 18.1°	12.1°x9.1°
Spatial resolution (IFOV)	1.84	0.92	0.68	0.34
Palette	10 color palettes			
Thermometric analysis	Infinite points, infinite boxes, infinite lines			
Object temperature range	-20 °C~150 °C (low temperature range), 0 °C~410°C (medium temperature range)			
Optional temperature range	+300 °C~+650 °C\+300 °C~+2000 °C\other ranges (high temperature range)			
Temperature measurement accuracy	±2°C or 2% of readings,maximum value			
Visible light performance				
Sensor type	1/2.8" Progressive Scan CMOS			
Resolution	1920×1080 2MP			
Focal length	4.8~120 mm, 25x optical zoom			
Field angle	57.6-2.5° (wide angle-telephoto)			
Minimum illumination	Color: 0.05 lux @ (F1.6, AGC ON) \ Black and white: 0.01 lux @ (F1.6, AGC ON)			
Focus	Manual/semi-automatic/automatic			
Wiper function	Support			
Fill light function	Infrared fill light, distance 150 meters			

PTZ performance	
Horizontal range	0~360° continuous rotation
Vertical range	-27°~90°
Positioning accuracy	±0.05°
Horizontal speed	0.05°~200°/s
Vertical speed	0.05°~120°/s
Number of preset points	255
Cruise scan	8 lines, 32 preset points can be added to each line
Interface	
Power interface	φ5.5*2.1 DC power interface
Network interface	One 10M/100M adaptive Ethernet port
Network protocol	TCP/IP,IPv4,HTTP,FTP,DDNS,DHCP,RTP,RTSP,UDP,NTP,IGMP,ICMP, ONVIF
Application programming interface	Support standard protocol (ONVIF), support SDK access
System parameter	
Voltage supply	AC24V (±20%) \ DC24V (±20%)
Power	≤40W
Operating temperature and humidity	-40°C~70°C, < 90% RH
Protection level	IP66
Weight	7.76kg
Shell material	Die-cast aluminum

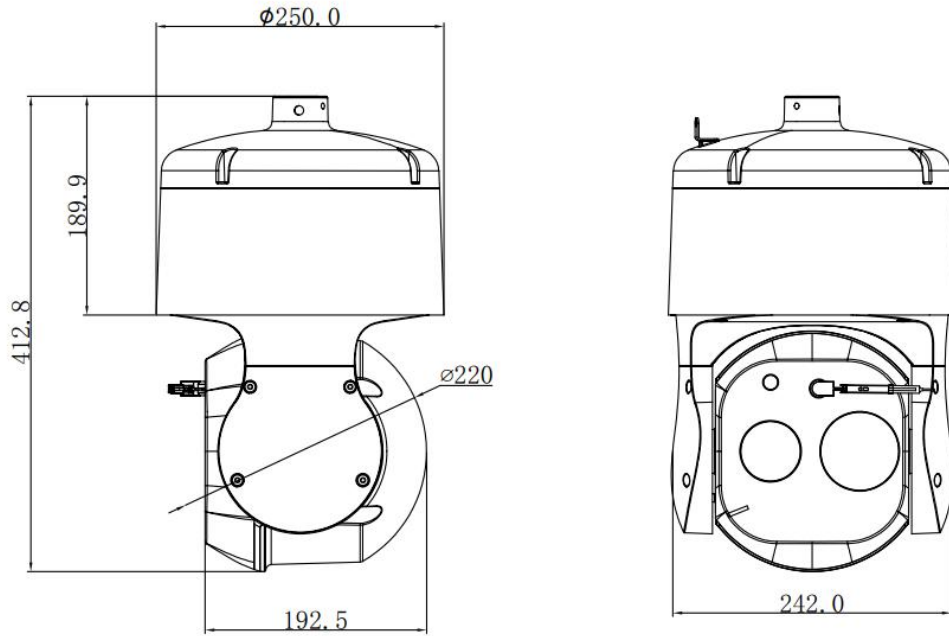
Product Size:

Unit: mm

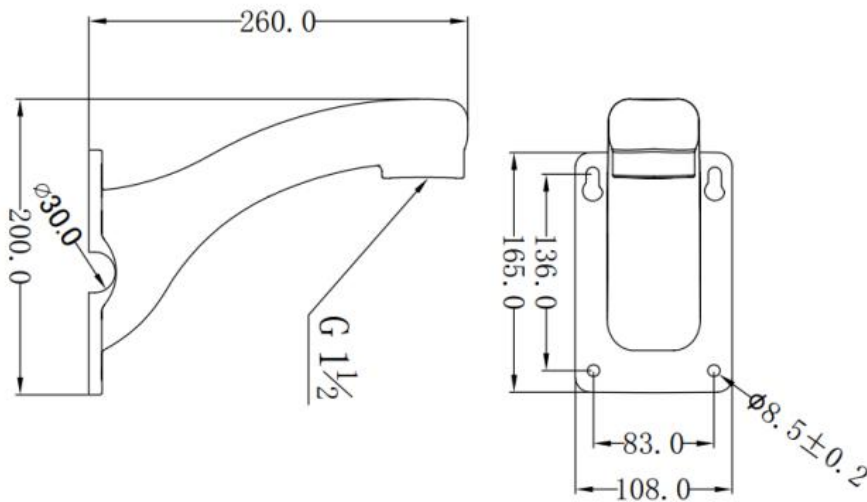
Wall Mount Bracket Dimensions:

Unit: mm